



PRICE: \$25.00

**OPERATING MANUAL
PCP/TPCP SERIES PowerCassette®
FRONT-END SWITCHERS**

www.unipowercorp.com

Manual No. TPCP-Man-204-1
PCP-TPCP-Man 02/04/04

© 2004 UNIPOWER Corp.
All Rights Reserved

UNIPOWER Corporation

NORTH AMERICA • 3900 Coral Ridge Drive, Coral Springs, Florida 33065, USA • Tel: +1 954-346-2442 • Fax: +1 954-340-7901 • sales@unipower-corp.com
EUROPE • Parkland Business Centre, Chartwell Road, Lancing BN15 8UE, ENGLAND • Tel: +44(0)1903 768200 • Fax: +44(0)1903 764540 • info@unipower-europe.com

CONTENTS

<u>SECTION</u>	<u>TOPIC</u>	<u>PAGE</u>
1.0	Introduction	1
2.0	PowerCassette Features	1
3.0	Summary of Product Line	3
4.0	Safety Warnings	4
5.0	Warranty	4
6.0	Unpacking and Inspection	5
7.0	Front Panel Description	5
8.0	PowerCassette Specifications	5
9.0	Description of Features and Options	8
10.0	Mechanical Specifications	9
11.0	Safety and Industry Standards	9
12.0	Operating Information	10
13.0	Parallel Operation	14
14.0	Compatible 19-Inch Racks	14
15.0	Description of Control & Supervisory Signals	19
16.0	Installation	20
17.0	Maintenance	20
18.0	PowerCassette Setup and Testing	20
19.0	Troubleshooting Guide	23
	Appendix: Data Sheet	A1

ILLUSTRATIONS

<u>FIGURE</u>	<u>TITLE</u>	<u>PAGE</u>
1	PowerCassette Front End Models PCP and TPCP	2
2	Front Panel of the PowerCassette Front End	2
3	IEC Input Version	6
4	Mechanical Dimensions of PowerCassette	6
5	Connectors and Pin Connections	11
6	Output Voltage Adjustment	12
7	Rated Total Output Power vs. Ambient Temperature	12
8	Remote Sensing Connection	12
9	Two-Unit Rack with Connections	15
10	Three-Unit Rack with Connections	16

OPERATING MANUAL

PCP/TPCP SERIES PowerCassette® NEXT GENERATION FRONT-END SWITCHER

1.0 INTRODUCTION

This operating manual should be read through carefully before installing and operating the PCP/TPCP Series PowerCassette®.

The PowerCassette is an advanced-design, front-end switching power supply that employs a unique, new architecture which permits quick factory programming of its output. There is a high current output and a 5VDC ¼ ampere independent standby output. Maximum continuous output power is 800, 1000 or 1200 watts, with available voltages of 12, 24 or 48VDC, respectively.

The PowerCassette front-end is ultra-compact, only 1.6 inches high, 5 inches wide and 10 inches deep, producing up to 15 watts per cubic inch power density. The unit comes in two versions: the PCP model which is the standard, non-hot-swap version, and the TPCP model, which is the hot-swap version with a handle and mounting bracket with jackscrews. See Figure 1.

PowerCassette incorporates control and monitoring features including enable and inhibit inputs, AC power fail and DC power good signals, overtemperature warning and remote sensing. The front panel has two LED status indicators: one for AC Power Good and the other for DC Power Good. The output has a single-wire, current sharing capability.

Two 19-inch, 1U-high racks are available to hold two or three PowerCassette units connected in parallel to give up to 1200 watts with 1+1 redundancy or 2400 watts with non-redundant operation for the two-unit rack or up to 2400 watts with 2+1 redundancy or 3600 watts with non-redundant operation for the three-unit rack. The racks feature IEC60320 AC input connections.

2.0 FEATURES

The following is a summary of the important features of the PowerCassette front-end:

- ◆ Includes Isolated 5V, ¼ A Standby Output
- ◆ Hot-Swap or Chassis Mount Versions
- ◆ 12, 24, or 48 VDC Outputs

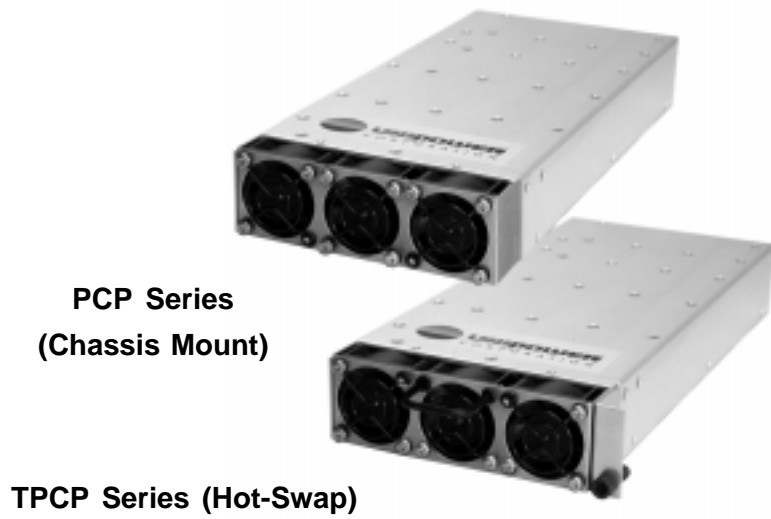

Figure 1. PowerCassette Front-End Models PCP and TPCP

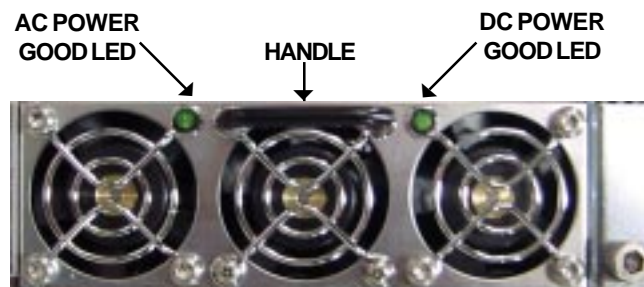

Figure 2. Front Panel of the PowerCassette Front End

- ◆ Integral LED Status Indicators
- ◆ Up to 15 Watts/Cubic Inch Power Density
- ◆ Power Factor Corrected
- ◆ Low Profile: 1.6 Inches High
- ◆ Single, Hot-Swappable Connector
- ◆ Staged Pin Lengths
- ◆ ORing Diode on Output
- ◆ 1U, 19" Racks Hold 2 or 3 Units*
- ◆ Active Current Sharing
- ◆ Universal 85 to 264VAC Input
- ◆ Class B EMI Input Filter
- ◆ I²C Serial Data Option
- ◆ Optimized Thermal Management
- ◆ No Minimum Load
- ◆ Control & Monitoring Features

*TCP Models

3.0 SUMMARY OF PRODUCT LINE

3.1 Standard Models

Delete "T" prefix to model no. for chassis mount version.

MAX. OUTPUT POWER	OUTPUT VOLTAGE	OUTPUT CURRENT	INPUT VOLTAGE	PFC	MODEL NUMBER
800W	12VDC	66.7A	85-264VAC	YES	TPCP3000
1000W	24VDC	41.7A	85-264VAC	YES	TPCP5000
1200W	48VDC	25.0A	85-264VAC	YES	TPCP7000

NOTE: The table does not show the independent 5V, ¼A standby output which is standard on all models.

3.2 Options

SUFFIX CODE	OPTION
Z	I ² C Serial Data Bus

3.3 19-Inch Compatible Racks. These racks hold two or three TCP units.

Rack Model No.: TPCMR1U2 for Two Units
 TPCMR1U3 for Three Units

4.0 SAFETY WARNINGS

- 4.1** These power supplies have hazardous external and internal voltages. They should be handled, tested and installed only by qualified technical persons who are trained in the use of power systems and are well aware of the hazards involved.
- 4.2** The input terminals are at hazardous voltage potentials. Do not touch this area when power is applied.
- 4.3** When operating this power supply, the chassis ground terminal must be connected to safety ground by means of a three-wire AC power line to minimize electrical shock hazard and to ensure low EMI (electromagnetic interference).
- 4.4** The internal voltages are at hazardous potentials. The power supply cover should not be removed. There are no user-serviceable components in these units. Removing the cover of the power supply will void the warranty.

5.0 WARRANTY

All products of UNIPOWER Corporation are warranted for two (2) years from date of shipment against defects in material and workmanship. This warranty does not extend to products which have been opened, altered or repaired by persons other than persons authorized by the manufacturer or to products which become defective due to acts of God, negligence or the failure of customer to fully follow instructions with respect to installation, application or maintenance. This warranty is extended directly by the manufacturer to the buyer and is the sole warranty applicable. EXCEPT FOR THE FOREGOING EXPRESS WARRANTY, THE MANUFACTURER MAKES NO WARRANTY, EXPRESS OR IMPLIED, INCLUDING, BUT NOT LIMITED TO, THE WARRANTY OF MERCHANTABILITY OR FITNESS FOR A PARTICULAR PURPOSE. As the sole and exclusive remedy under this warranty, the manufacturer, at its option, may repair or replace the non-conforming product or issue credit, provided the manufacturer's inspection establishes the existence of a defect. To exercise this remedy, the buyer must contact the manufacturer's Customer Service Department to obtain a Return Material Authorization number and shipping instructions. Products returned without prior authorization will be returned to buyer. All products returned for repair must be shipped freight prepaid to UNIPOWER. If the buyer fails to fully comply with the foregoing, the buyer agrees that no other remedy (including, but not limited to, incidental or consequential damages for lost profits, lost sales, injury to person or property or any other incidental or consequential losses) shall be available to the buyer.

6.0 UNPACKING AND INSPECTION

- 6.1 This PowerCassette was carefully tested, inspected and packaged for shipment from our factory. Upon receipt of the unit it should be carefully unpacked and inspected for any damage in shipment.
- 6.2 If there is evidence of damage, do not attempt to test the unit. The freight carrier should be notified immediately and a claim for the cost of the power supply should be filed with the carrier for direct reimbursement. Be sure to include the model and serial number of the damaged unit in all correspondence with the freight carrier. Also save the shipping carton and packing material as evidence of damage for the freight carrier's inspection.
- 6.3 UNIPOWER Corporation will cooperate fully in case of any shipping damage investigation.
- 6.4 Always save the packing materials for later use in shipping the unit. Never ship the power supply without proper packing.

7.0 FRONT PANEL DESCRIPTION

The front panel of the PowerCassette is shown in Figure 2. On the left top of the panel is the AC Power Good LED (green) and on the right top is the DC Power Good LED (green). For the TPCP model there is a handle between the two LEDs. Also for this model there is a mounting bracket on the right side of the front panel. This has a jackscrew (Allen bolt) for securing the unit.

8.0 POWERCASSETTE SPECIFICATIONS

Typical at 120/230VAC Line, Full Load and 25°C Unless Otherwise Noted.

OUTPUT SPECIFICATIONS

Total Output Power, Continuous, Max.	800-1200 Watts
Voltage Adjustment Range, Min.	±5%
Total Regulation ¹ ,	2.0%
Total Regulation ¹ , Standby Supply	5.0%
Ripple & Noise, Pk-Pk ²	1%
Holdup Time	20mS
Dynamic Response ³	300µS
Temperature Coefficient	±0.02%/°C
Minimum Load, Any Output	0A
Overload Protection	Auto Recovery
Overvoltage Protection	Latched Shutdown
Remote Sense	Up to 0.25V Per Wire
Current Share	±10% Full Load Rating

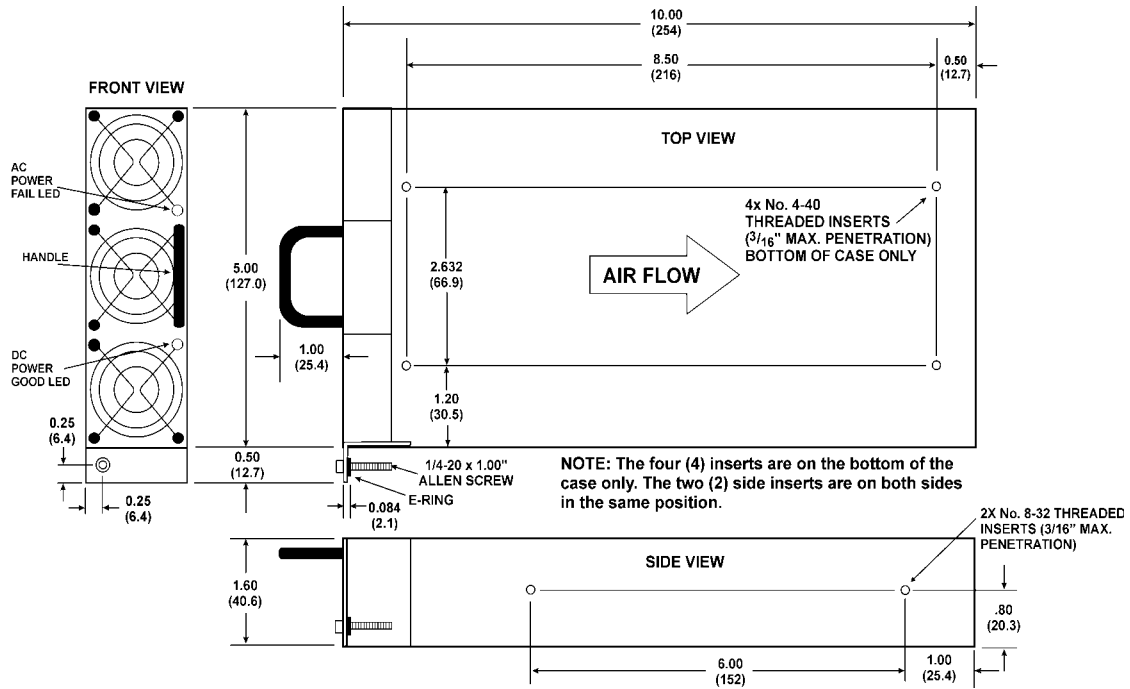

NOTE: The TCP Model is shown. The PCP version does not have handle or mounting bracket with bolt. Maximum torque on the threaded inserts is 6 inch-pounds.

Figure 3. Mechanical Dimensions of PowerCassette

Standby Output	+5V, 250mA
DC Power Good Signal	Logic Low
AC Power Fail Signal	Logic High
Inhibit	Logic Low
Enable	Logic Low
Thermal Warning	Logic High

INPUT SPECIFICATIONS

Input Voltage Range	85-264VAC
Power Factor	0.99
Input Frequency	47-63Hz
Inrush Current Limiting	50A Peak
Input EMI Filter	EN55022 Curve B FCC20780 pt. 15J Curve B
Harmonic Distortion	EN61000-3-2
Input Immunity, Conducted	
Fast Transients, Line-Line	±2kV (EN61000-4-4 Level 3)
Surges, Line-Line	±2kV (EN61000-4-5 Level 3)
Surges, Line-Ground	±4kV (EN61000-4-5 Level 4)
Input Protection	Internal Fuse, 20A

GENERAL SPECIFICATIONS

Efficiency ⁴	75-85% at Full Load
Switching Frequency, PFC Converter	48-110kHz
Output Converter	275kHz Nominal
Isolation, Class I, min. ⁵	
Input-Output	3000VAC
Input-Ground	1500VAC
Output-Ground	50VDC
MTBF (Bellcore)	200,000 Hours
Safety Standards	EN60950, UL1950, CSA22.2 No.950

ENVIRONMENTAL SPECIFICATIONS

Operating Temperature	0°C to 70°C Ambient
Derating	2.5% / °C, 50°C to 70°C
Storage Temperature	-40°C to +85°C
Cooling	Integral Ball Bearing Fans

PHYSICAL SPECIFICATIONS

Case Material	Aluminum
Dimensions, Inches(mm)	1.6 H x 5.0 W x 10.0 D (40.6 x 127 x 254)
Weight	3.15 lbs. (1.43 kg.)

NOTES:

1. No load to full load, including line regulation and load regulation.
2. Whichever is greater. 20MHz bandwidth. Measure with 0.1µF ceramic and 10µF tantalum capacitors in parallel across the output.
3. <4% deviation recovering to within 1% for 25% load change.
4. Typical efficiency is at low end of range for 12V output and at high end of range of 48V output.
5. Input-output isolation figure is for isolation components only.
100% production Hipot tested.

9.0 DESCRIPTION OF FEATURES & OPTIONS

FEATURE / OPTION	DESCRIPTION
Power Factor Correction	The input current is a sine wave in-phase with the input voltage to give a power factor of 0.99. Input current total harmonic distortion meets EN61000-3-2.
Wide Range AC Input	The AC input range is continuous from 85 to 265VAC, 47-63Hz, for worldwide operation.
EMI Input Filter	This filter suppresses conducted noise from the supply back onto the AC line. The filter meets FCC20780 part 15J Curve B and EN55022 Curve B.
Inrush Current Limiting	When the unit is turned on, the initial input current is limited to a peak value of 50 amperes AC. This is accomplished by an active current limiting circuit (not a thermistor).
Thermal Protection	If the PowerCassette overheats internally, it will automatically shut down. The DC Power Good LED turns off. The Overtemperature Warning goes HI and the DC Power Good signal goes HI. After a few minutes the unit will cool down and automatically start up again.
Current Sharing	The PowerCassette front end will automatically current share with another identical unit. A single-wire connection provides this. The output actively current shares with an accuracy of 10% of full load output current for a total load of 50% to 100%.
ORing Diodes	A diode in series with the output protects the output of parallel-connected PowerCassettes. If one output fails to a short or to a lower than normal output voltage, the other output is not affected. Also when hot-swapping units in the rack, the diode prevents a glitch in the output voltage while the output is still rising on the inserted supply. The 5V, ¼A standby output also has an ORing diode.
5V, ¼A Standby Output	This is an independent output which is not controlled by the Enable or Inhibit inputs. This output also has an ORing diode and can be paralalled with another PowerCassette Standby Output.
Overvoltage Protection	The output is protected from overvoltage due to fault conditions in the supply. Overvoltage protection is set at approximately 10% above the nominal output voltage level. The result is a latched shutdown of the supply. It is reset by cycling the AC input off and then back on.
No Load Operation	The PowerCassette output can be operated down to zero load while maintaining output regulation.

FEATURE / OPTION	DESCRIPTION
Hot-Swap Connectors	The hot-swap connectors used in both the PowerCassette and rack are specifically designed for hot-swap applications. They have staged pin engagement for safety and optimum operation. The ground (common) and AC pins make first contact and the enable pin makes last contact, turning the unit on (provided it is not “inhibited”).
Hot-Swap Operation	Hot-swap operation means that a PowerCassette can be removed and replaced while the rack is powering the load. If the rack is operated in a redundant mode, hot-swap replacement will not affect the output voltage.
Output Protection	Output current limiting protects the output of the PowerCassette from damage due to an overload or short circuit condition. This protection is continuous, without damage, and recovery is automatic when the overload is removed. Current limiting begins at about 105% of rated output current.
LED Indicators	The AC Power Good indicator is a green LED, showing that input power is present. The DC Power Good indicator is a green LED showing that the output voltage is present and within operating range.
Control and Monitoring Signals	For detailed descriptions of Enable/Inhibit, Current Share, Remote Sense, Input Power Fail and Output Power Good signals, see Section 15, Description of Control and Supervisory Signals.

10.0 MECHANICAL SPECIFICATIONS

The mechanical dimensions of the PowerCassette are shown in Figure 3. Please note the maximum torque on the threaded inserts.

11.0 SAFETY AND INDUSTRY STANDARDS

11.1 The PowerCassette meets the following safety certifications:

STANDARD	AGENCY
UL1950	UL
CSA22.2 No.950	CUL
EN60950	DEMKO

- 11.2 The PowerCassette is CE marked to indicate conformance to the European Union's Low Voltage Directive.
- 11.3 Input conducted EMI meets FCC20780 part 15J Curve B and EN55022 Curve B.
- 11.4 The input immunity, conducted, meets the following. Input fast transients, line-to-line, meet EN61000-4-4 Level 3; input surges, line-to-line, meet EN61000-4-5 Level 3; and input surges, line-to-ground, meet EN61000-4-5 Level 4.

12.0 OPERATING INFORMATION

- 12.1 **Input Voltage and Connection.** The PowerCassette operates off world-wide AC input voltages in the range of 85 to 264 VAC at 47 to 63 Hz. The three-wire AC connection is made to pins 22-24 on the Positronics connector. See the connector diagram and Pin Connections table in Figure 4a.
- 12.2 **Output Connections.** The output voltage is provided on pins 1 to 6 of the Positronics connector. Three pins (1 to 3) are connected together internally for the +V Out; three other pins (4 to 6) are connected together internally for the V Return.
- 12.3 **Mating Interface Board.** Figure 4b shows a mating interface board which is available for simplifying the testing of a PCP/TPCP PowerCassette. As shown in the photograph, provision is made for input and output connections, and also for the control and monitoring signals.
- 12.4 **Output Voltage.** The output voltage is factory set to its nominal value to an accuracy of $\pm 1\%$. The voltage can be more accurately adjusted to a value within a $\pm 5\%$ range by means of external components as shown in Figure 5.
- 12.5 **Output Power.** The maximum continuous output power is 800 watts for the 12V output, 1000 watts for the 24V output, and 1200 watts for the 48V output. The 5V standby output produces 1.25 watts.

The maximum output power of a PowerCassette may be drawn up to 50°C ambient temperature. Above 50°C the total output power must be derated by 2.5%/°C. See Figure 6. The maximum operating ambient temperature is 70°C, at which the total output power must be derated by 50%.

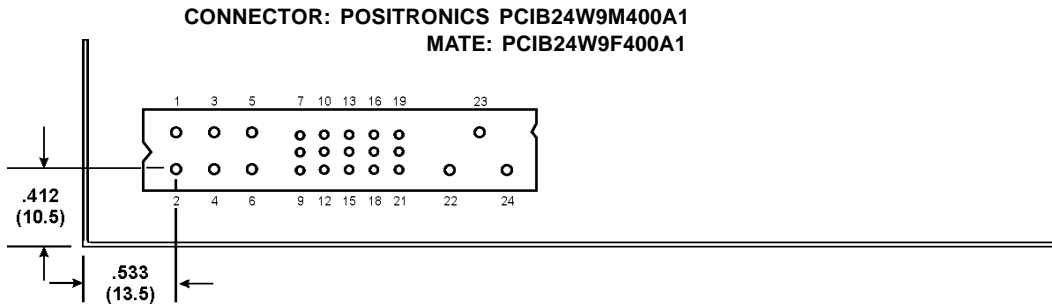

PIN CONNECTIONS			
PIN	FUNCTION	PIN	FUNCTION
1	+V Out	13	Spare
2	+V Out	14	DC Power Good/ ADD GA1*
3	+V Out	15	AC Power Fail
4	V Return	16	V Trim
5	V Return	17	Overtemp. Warning/ ADD GA0*
6	V Return	18	Current Share
7	Enable*	19	Current Monitor/ ADD GA2*
8	+ Sense	20	+5V Standby
9	- Sense	21	Standby Return
10	Inhibit	22	Chassis Ground
11	Spare/ SDA*	23	AC Line
12	Spare/ SCL*	24	AC Neutral

MATING CONNECTOR KIT
Order Kit No. 775-1449-0000

MATING INTERFACE BOARD
Order Kit No. 009-3736-0000

***NOTE:** For unit to operate, pin 7 must be at logic LO or shorted to pin 9. For proper operation the following pins must be connected together: All V Out pins (1-3); all V Return pins (4-6). Pins 11, 12, 14, 17 & 19 function as I²C outputs when that option is present.

Figure 4a. Connector and Pin Connections to PowerCassette

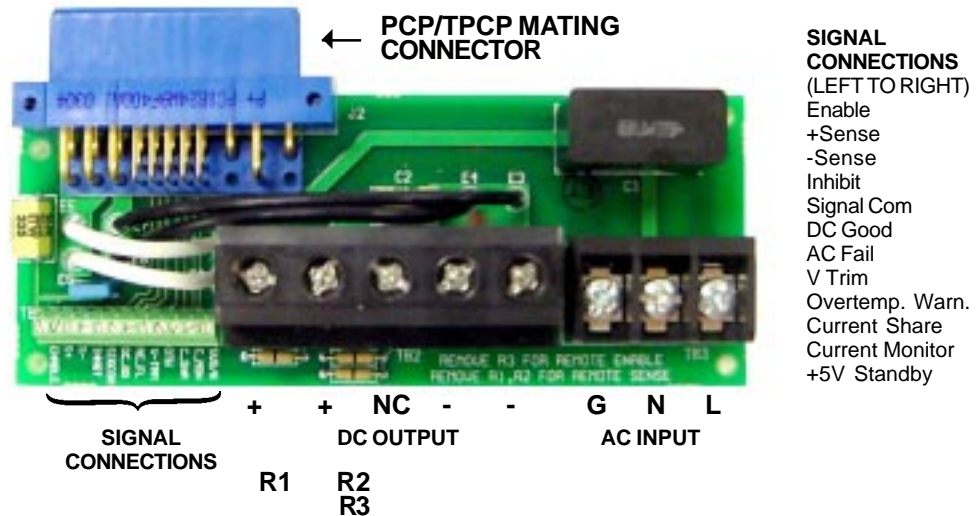
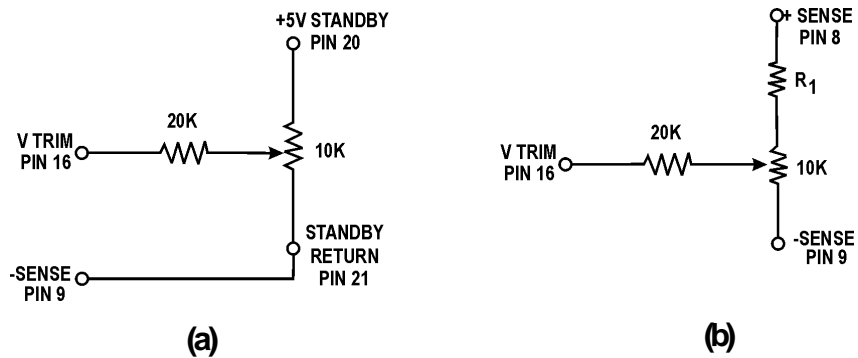

Figure 4b. Mating Interface Board



OUTPUT	R1*
12V	12K
24V	33K
48V	75K

* Resistors are 5%, 1/8W.

Figure 5. Output Voltage Adjustment Methods

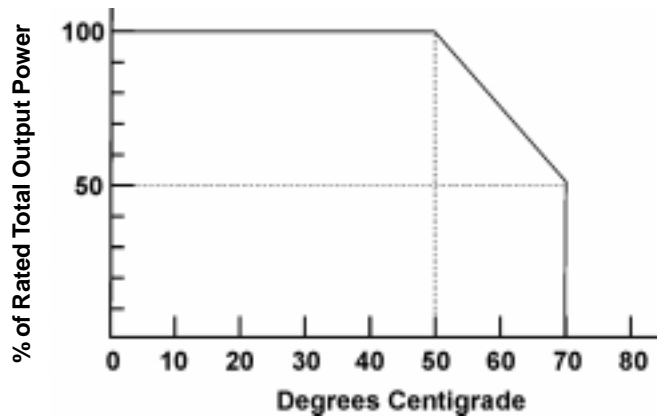

Figure 6. Rated Total Output Power vs. Ambient Temperature

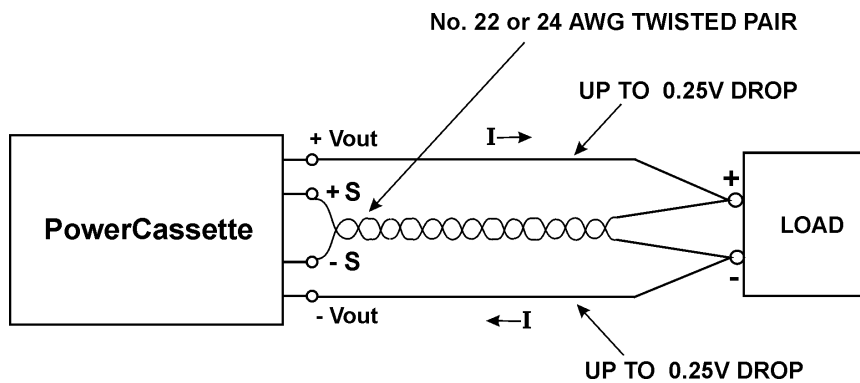

Figure 7. Remote Sensing Connection

12.6 Output Overload Protection. The PowerCassette output is protected from damage due to an overload or short circuit condition. This protection is continuous and without damage; recovery is automatic when the overload or short circuit condition is removed. PowerCassette incorporates a “straight line” method of current limiting. When the output current reaches an overload threshold, the voltage begins to drop sharply so that the current, with a given overload impedance, forces the voltage to a level which maintains the current at an equilibrium point.

12.7 Remote Sensing. Remote sensing connections are made to pins 8 and 9 on the Positronics connector. Remote sensing is not available on the Standby +5V, ¼ ampere output. Remote sensing is used to regulate the output voltage at the point of load by compensating for the voltage drop in the wires to the load. The +Sense lead (Pin 8) must be connected to the + side of the load and the -Sense lead (Pin 9) to the -side of the load. The sense leads should be a color-coded, twisted pair of AWG no. 22 or 24 copper wire. See Figure 7.

Remote sensing can compensate for a total voltage drop of 0.5V, or 0.25V per load wire. The sense leads should not exceed 10 feet (3 meters) in length. If remote sensing is not required, the sense leads may be left open for local sensing at the output terminals. **Be careful not to reverse the sense lead connections, as this could damage the output.**

12.8 Control & Supervisory Signals. All control and supervisory signals are accessible at the Positronics connector on the back of the unit. See Figure 4. See Section 15 for a complete description of these input and output signals.

12.9 Alarm Signals. Among the control and supervisory signals are three logic alarms: AC Power Fail, DC Power Good and Overtemperature Warning. These are logic signals referenced to -Sense, Pin 9 on the Positronics connector. AC Power Fail is a logic LO when AC input power is present. This signal goes to a HI 4 milliseconds before the outputs go out of regulation and stays HI for typically 15 msec. DC Power Good is a logic LO when the output is present and in regulation and goes to a HI when there is output failure. Overtemperature Warning is normally a logic LO but goes to a HI when the internal air temperature reaches a critical level just prior to the unit shutting down.

13.0 PARALLEL OPERATION

13.1 Parallel Connection. Two or more PowerCassettes can be operated in parallel by connecting their outputs in parallel and connecting their current share terminals, together (pin 18). The PowerCassette racks permit conveniently operating two or three units in parallel in either a 1+1 or 2+1 redundant mode or non-redundant mode.

13.2 Redundant Operation. Connecting two PowerCassettes in parallel, with or without the compatible 19-inch rack, so that the full output load current can be carried by one unit results in 1+1 redundant operation. While operating normally, the load current is shared approximately equally between the two units. Should one PowerCassette fail, the full load is then maintained by the other unit. The failed unit can then be replaced (hot-swap) without affecting the load current. This operation is facilitated by the ORing diode on the output. 1+1 redundancy with quick replacement of a failed unit results in virtually infinite MTBF. 2+1 redundancy works the same way except that the full load is carried by two out of three units.

13.3 Non-Redundant Operation. Higher output load currents can be realized by operating two or three units in the non-redundant mode to achieve up to 2400 watts for two units or 3600 watts for three units. The units are connected in parallel the same as before. In this case if one unit fails, the load will lose power since only part of the load current can now be supplied by the remaining unit(s), which will go into current limit. The failed unit can be quickly replaced, however, without turning the power off (hot-swap) to restore load current.

14.0 COMPATIBLE 19-INCH RACKS

14.1 There are two 19-inch compatible racks. One holds two PowerCassette TPCP units and the other holds three. See Figures 8 and 9. These racks have the following features:

- Standard 19-Inch Racks
- Only 1U High
- Hot-Swap Operation
- Holds Two or Three TPCP Units
- Class B EMI Input Filter
- Up to 2400W or 3600W Non-Redundant

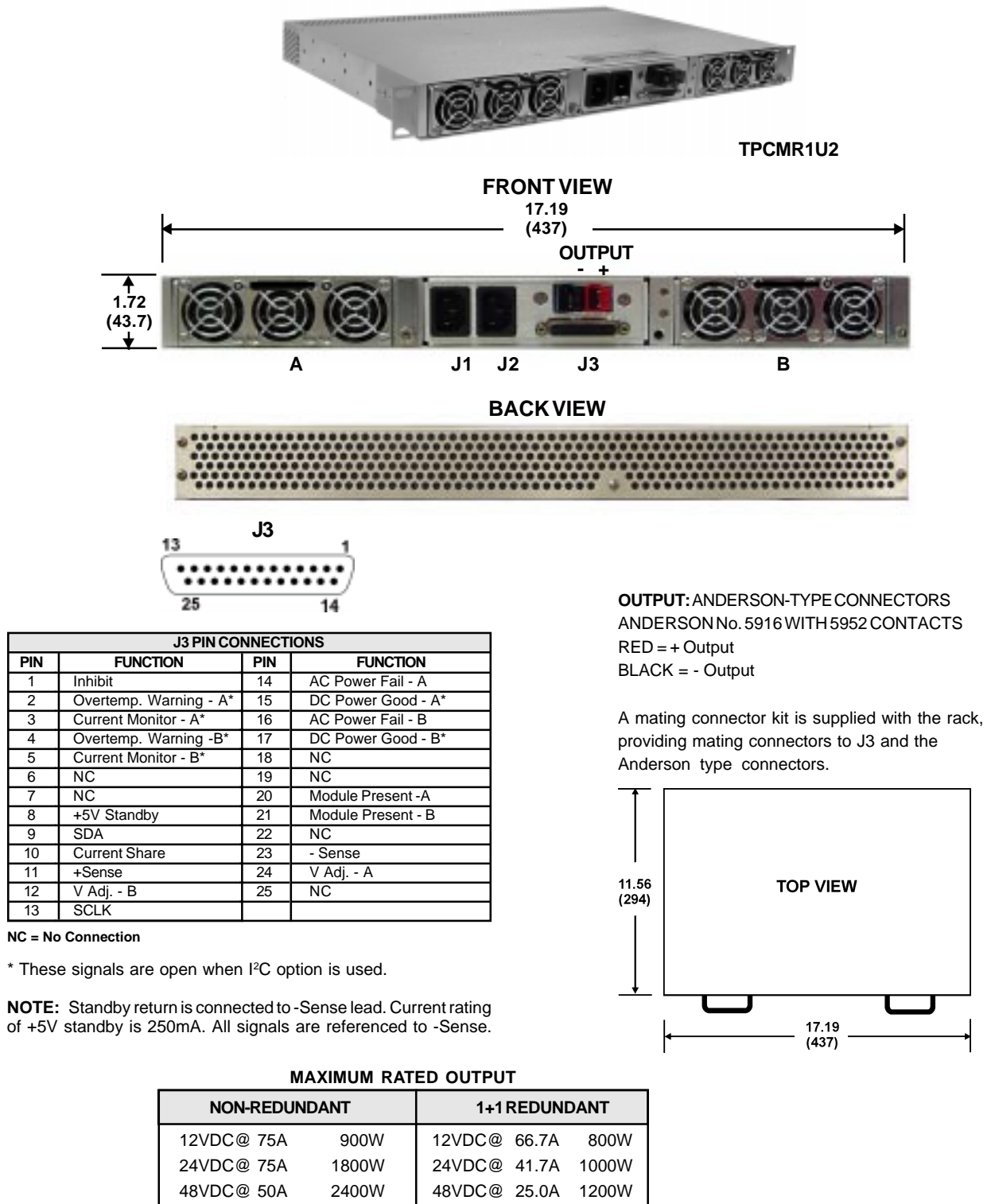
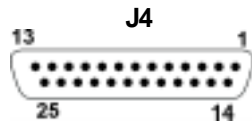
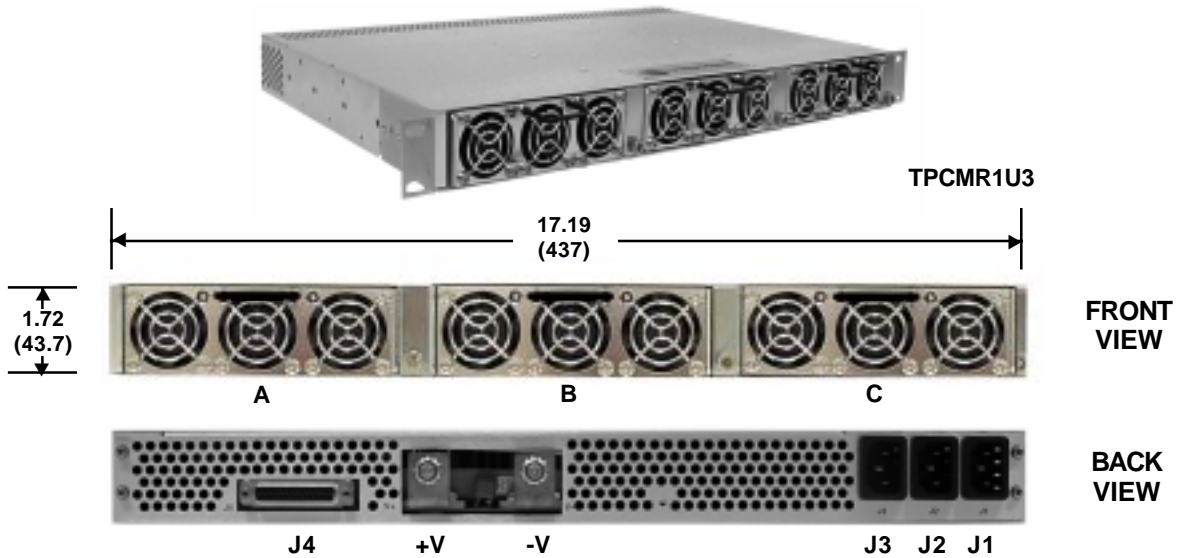

Figure 8. Two-Unit Rack with Connections



J4 PIN CONNECTIONS			
PIN	FUNCTION	PIN	FUNCTION
1	Inhibit	14	AC Power Fail - A
2	Overtemp. Warning - A*	15	DC Power Good - A*
3	Current Monitor - A*	16	AC Power Fail - B
4	Overtemp. Warning - B*	17	DC Power Good - B*
5	Current Monitor - B*	18	AC Power Fail - C
6	Overtemp. Warning - C*	19	DC Power Good - C*
7	Current Monitor - C*	20	Module Present - A
8	+5V Standby	21	Module Present - B
9	SDA	22	Module Present - C
10	Current Share	23	- Sense
11	+Sense	24	V Adj. - A
12	V Adj. - B	25	V Adj. - C
13	SCLK		

* These signals are open when I²C option is used.

NOTE: Standby return is connected to -Sense lead. Current rating of +5V standby is 250mA. All signals are referenced to -Sense lead.

OUTPUT: Copper bus bars with no. 1/4-20 studs with nuts.

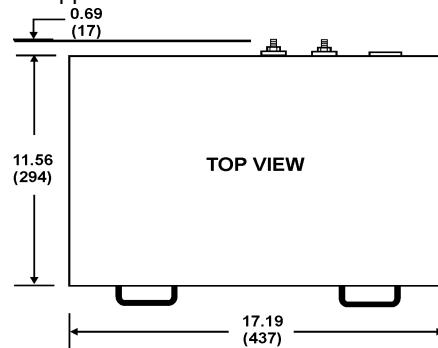

MAXIMUM RATED OUTPUT			
NON-REDUNDANT		2+1 REDUNDANT	
12VDC @ 150A	1800W	12VDC @ 133.3A	1200W
24VDC @ 125A	3000W	24VDC @ 83.3A	1400W
48VDC @ 75A	3600W	48VDC @ 50.0A	1600W

Figure 9. Three-Unit Rack with Connections

- Up to 1200W or 2400W N+1 Redundant
- Current-Shared Outputs
- IEC60320 AC Inputs
- Front or Rear Access
- I²C Serial Data Bus Option
- Optional 23-Inch Mounting (with brackets)
- Module Present Signal

14.2 Ordering Guide

RACK MODEL NO.	MAX. NO. MODULES	CONNECTIONS	MAX. POWER
TPCMR1U2	2	All Front Entry	1600W
TPCMR1U3	3	All Rear Entry	2400W

14.3 Two-Unit Rack. The two-unit 19-inch rack is shown in Figure 8 together with connectors and pin designations. AC inputs are to two IEC60320 connectors, one for each PowerCassette module. The DC output is at two Anderson connectors. Monitoring and control signals are brought out at a 25-pin sub-miniature D-connector, J3. The maximum rated output figures for two modules in this rack must be observed as shown in the table. Note that the 12V output current is limited by the rack to 75 amperes, less than the total of two modules.

- 14.3.1** Input voltage range is 85-264VAC for maximum power in either redundant or non-redundant operation. The Class B EMI input specifications are met.
- 14.3.2** The outputs of the two PowerCassette modules are connected in parallel in the rack.
- 14.3.3** The rack depth is 11.56 inches (294mm).
- 14.3.4** Module A is on the left and module B on the right as seen from the front of the rack. AC input connector J1 goes to module A and J2 to module B.
- 14.3.5** For details on I²C data (J3 pins 9 and 13) check with factory.

14.3.6 The Module Present outputs (J3 pins 20 and 21) are grounded (to -Sense) when the module is plugged in and open when the module is out.

14.4 Three-Unit Rack. The three-unit 19-inch rack is shown in Figure 9 together with connectors and pin designations. The AC input connectors are IEC60320. All connections are at the rear of the rack. The DC output is at two copper bus bars with no. ¼-20 studs and nuts. Monitoring and control signals are brought out at a 25-pin subminiature D connector, J4. The maximum rated output figures for three modules are shown in the table. Note that the maximum output of a three-module, 12V unit is 150A, or 1800 watts, less than the total capability for the three 800 watt units.

14.4.1 All electrical connections are made to the rear of the rack. There is one AC connector for each module. Connector J1 goes to module A, connector J2 to module B and connector J3 to module C.

14.4.2 Module A is on the left, module B in the center and module C on the right, as seen from the front of the rack.

14.4.3 The outputs of all PowerCassette modules are connected in parallel in the rack.

14.4.4 The rack depth is 11.56 inches (294mm).

14.4.5 Input voltage range is 85-264VAC for maximum power in either redundant or non-redundant operation.

14.4.6 The Module Present outputs (J4 pins 20, 21 and 22) are grounded (to -Sense) when the module is plugged in and open the module is out.

14.4.7 For details on I²C data (J4 pins 9 and 13) check with factory.

15.0 DESCRIPTION OF CONTROL AND SUPERVISORY SIGNALS

SIGNAL	PINS	DESCRIPTION
Enable	7	A logic LO or short to Pin 9 enables (turns on) the unit. A logic HI or open inhibits (turns off) the unit. This input is referenced to - Sense, Pin 9. <u>This pin must be activated to a logic LO or short for the PowerCassette to operate.</u>
± Sense	8 & 9	These remote sense leads should be connected as a twisted pair to the respective + and - load points to provide regulation at the point of load. The correct polarities must be maintained.
Inhibit	10	A logic LO or short to Pin 9 turns off the output; a logic HI or open at this pin turns on the output. This input is referenced to -Sense, Pin 9.
DC Power Good	14	A logic LO indicates that the unit is operating properly with output voltage in its controllable range. A logic HI indicates output failure. The equivalent circuit is an NPN transistor collector with a 10K ohm resistor to +5V. This signal is referenced to - Sense, Pin 9.
AC Power Fail	15	A logic LO indicates the AC power is present; a logic HI indicates AC power failure. The signal goes HI 4 msec. before the output goes out of regulation and stays HI typically for 15 msec. The equivalent circuit is an NPN transistor collector with a 10K ohm resistor to +5V. This signal is referenced to - Sense, Pin 9.
External Trim	16	This is the connection for the output external trim. The voltage can be adjusted over a ±5% range from nominal using the external circuits shown in Figure 5.
Overtemperature Warning	17	A logic HI at this output indicates an overtemperature condition inside the unit. The HI occurs a few milliseconds before the unit shuts down. This output is referenced to -Sense, Pin 9.
Current Share	18	This analog signal is used to connect to the same pin of another identical PowerCassette to share output currents. Output currents between units are shared within an accuracy of 10% of full load current over a 50% to 100% load range. This signal is referenced to - Sense, Pin 9.
Standby Supply	20	This is a +5VDC, ¼A auxiliary output for powering external control or other circuits. The return is the Standby Return, Pin 21. This output is not controlled by the Enable or Inhibit inputs.

16.0 INSTALLATION

- 16.1 Mounting.** The PowerCassette can either be mounted in the 19-inch rack (model TPCP) and secured by means of the jack screw or it can be mounted (model PCP) on another metal chassis by means of no. 4-40 screws into the four threaded inserts on the bottom of the PowerCassette. It can also be mounted by the two no. 8-32 inserts on either side of the case. Maximum penetration for each is 3/16-inch. Maximum torque on each insert is 6 inch-pounds. See Figure 3.
- 16.2 Input Power Connections.** AC input power connections are made to pins 22, 23 and 24 of the Positronics connector. A three-wire AC line cord should be used with the safety ground connected to pin 22. See Figure 4.
- 16.3 DC Output Connections.** The DC output connections for the PowerCassette are shown in Figure 4. The output uses multiple, paralleled pins on the Positronics connector, namely pins 1 to 6. Pins 1 to 3 are +V Out and pins 4 to 6 are V Return.
- 16.4 Control and Supervisory Signal Connections.** These connections are made to various pins from 7 to 21 on the Positronic connector on the PowerCassette. See Figure 4. Details for these functions are given in Section 15.
- 16.5 Cooling.** The PowerCassette is cooled by three 40mm DC ball bearing fans. For proper cooling, the area in front of the fans and the back of the unit should be kept clear for unimpeded air flow.

17.0 MAINTENANCE

No routine maintenance is required on the PowerCassette Series except for periodic cleaning of dust and dirt around the fans. A small vacuum nozzle should be used for this.

18.0 POWERCASSETTE SETUP AND TESTING

- 18.1** The PowerCassette can be initially tested mounted in a rack or on a test bench. If two units are to be tested in a rack, they should first be individually tested in Position A (left side) of the rack.

- 18.2** With the input power source turned off, connect input power wires to the PowerCassette mating connector or in case of the rack to the input connector on the A side of the rack. Make sure that the safety ground wire is connected. Do not touch the output terminals when AC input power is present.
- 18.3** Connect a resistive power load across the proper output pins. The load should be 20% to 50% of full load value and can be either a power resistor or electronic load set to the resistive mode. Make sure that the power resistor has adequate heat sinking and cooling.
- 18.4** Connect a color-coded, twisted pair (no. 22 or 24 AWG) from the remote sense pins on the mating connector to the load. **The +Sense pin must go to the positive side of the load and the -Sense pin to the negative side of the load. Also connect the Enable pin, pin 27 of the Positronics mating connector of the PowerCassette, to the - Sense, pin 9. This must be done for the unit to operate.** When using the rack, the Enable pin is automatically connected to - Sense in the rack. The units are then controlled by the Inhibit inputs.
- 18.5 Checking Front Panel LEDs.** With the PowerCassette on the bench or in Position A of the rack, turn on (or plug in) the power source. The AC Power Good (bottom left) green LED should be on and the DC Power Good (bottom right) green LED should also be on.
- 18.6 Checking the Output Voltage.** Measure the output voltage at its load with a digital voltmeter. The voltage should be within $\pm 1\%$ of its nominal value.
- 18.7 Checking the Inhibit Input.** Unplug the input power source. Connect a wire from the Inhibit input (pin 10 on the PowerCassette Positronics connector) to - Sense, pin 9.

Turn the input power source back on. The AC Power Good green LED should turn on but the DC Power Good green LED should remain off. Check the output voltage with a digital voltmeter. It should read zero volts.

- 18.8 Checking the AC Power Fail and DC Power Good Signals.** Next check the voltage on the AC Power Fail pin (pin 15 on the PowerCassette Positronics connector) with respect to - Sense (pin 9). The voltage should be a logic LO, +0.5V or less. Finally, check the voltage on the DC Power Good pin (pin 14) with respect to - Sense (pin 9). The voltage should be a logic HI, approximately +5V.

Disconnect the wire from the Inhibit to - Sense. The DC Power Good green LED should turn on. Check the output voltage on the DC Power Good pin as described above. The voltage should be a logic LO, +0.5V or less.

18.9 Testing the Other Power Cassettes. For a rack with two or three PowerCassettes, the other PowerCassettes should be plugged into Position A in the rack and tested in the same manner as above in Sections 18.2 to 18.8.

18.10 Testing the Complete Power Cassette Rack. With the input power source off or disconnected, insert all PowerCassettes into the rack. Connect a resistive power load of approximately 80% of full load value for a single PowerCassette across the output. Connect a color-coded, twisted pair of remote sense leads to the load, **being careful to connect the correct polarity.**

Turn on or plug in the input power source. Check the voltage across the load with a digital voltmeter. The voltage should be within about $\pm 1\%$ of its **nominal value. The AC Power Good and DC Power Good green LEDs should be on for both units.**

While the rack is operating, disengage PowerCassette A (left one) and check the output voltage. It should be very close to the previous value and the DC Power Good green LED should remain on for PowerCassette B (and C) which are now carrying the full power load. Re-insert PowerCassette A and repeat the procedure by disengaging PowerCassette B (then C). The complete rack has now been shown to operate properly in the redundant mode with hot swapping. Disconnect the input power source.

19.0 TROUBLESHOOTING GUIDE

19.1 If you encounter difficulties in getting the PowerCassettes or the complete rack to operate properly, go through the following troubleshooting guide.

19.2 Table 19-1. PowerCassette and Rack Troubleshooting

SYMPTOM	POSSIBLE CAUSE	ACTION TO TAKE
No output, AC Fail and DC Good LEDs off.	No AC power.	Check connection to AC power source. Check source circuit breakers.
No output, DC Good LED off, AC Good LED on.	Remote Enable in OFF mode.	Make sure Pin 7 (Enable) is at logic LO or connected to - Sense, Pin 9, of the Positronics connector.
No output, DC Good LED off, AC Good LED on.	Shorted output.	Check for short and remove.
No output, DC Good LED off, AC Good LED on.	Overvoltage protection (OVP) has latched.	Reset output by cycling the input power OFF for 10 seconds and then back ON.
No output, DC Good LED off, AC Good LED on.	Overtemperature protection is activated.	Allow PowerCassette to cool down for about 10 minutes. It will then start up automatically. Check to see if the cooling fans are operating.
No output, DC Good LED off, AC Good LED on.	Total output load is too large for the PowerCassette capacity.	Reduce loads to proper levels.

19.3 If none of the above actions solves the problem, call UNIPOWER Corporation at 954-346-2442 Ext. 400 for help and try to resolve the problem over the telephone.

PowerCassette®: NEXT GENERATION FRONT-END SWITCHER

1U High, Up to 1200 Watts with PFC and Integral Hot Swap Provision

FEATURES

- Includes Isolated 5V, ¼ A Standby Output
- Hot-Swap Operation
- 12, 24 or 48 VDC Outputs
- Integral LED Status Indicators
- I²C Serial Data Bus Option
- Up to 15 Watts/Cubic Inch
- Power Factor Corrected
- Low Profile: 1.6 Inches High
- Single Hot-Swappable Connector
- Staged Pin Engagement
- ORing Diode on Output
- 1U, 19" Rack Holds 2 or 3 Units*
- Active Current Sharing
- Universal 85 to 264VAC Input
- Class B EMI Input Filter
- Optimized Thermal Management
- No Minimum Load
- Control & Monitoring Features

*TCPM Models

PCP Series
(Chassis Mount)

TPCP Series
(Hot-Swap)

1U High
1.6" x 5" x 10"
(41 x 127 x 254 mm)

Two-Unit Rack

Three-Unit Rack



LVD73/23/EEC

TWO-YEAR WARRANTY

Patents Issued & Pending

STANDARD MODELS

Delete "T" prefix to model no. for chassis mount version.

MAX. OUTPUT POWER	OUTPUT VOLTAGE	OUTPUT CURRENT	INPUT VOLTAGE	PFC	MODEL NUMBER
800W	12VDC	66.7A	85-264VAC	YES	TCPM3000
1000W	24VDC	41.7A	85-264VAC	YES	TCPM5000
1200W	48VDC	25.0A	85-264VAC	YES	TCPM7000

NOTE: The table does not show the independent 5V, ¼A standby output which is standard on both models.

CODE	OPTION
Z	I ² C Serial Data Bus

NOTE: Add Option Code as suffix to model no.
Contact factory on availability of Option Z.

SAFETY CERTIFICATIONS

AGENCY	STANDARD
UL	UL1950
CUL	CSA22.2, No. 950
DEMKO	EN60950

SHELF ORDERING GUIDE:

For 1U, 19-inch rack holding two TCPM models, order TCPMR1U2; for 1U 19-inch rack holding three TCPM models, order TCPMR1U3. See separate data sheet for racks.

SPECIFICATIONS, *PowerCassette*[®] PCP & TCP SERIES FRONT ENDS

Typical at Nominal 115/230VAC Line, Full Load and 25°C Unless Otherwise Noted.

OUTPUT SPECIFICATIONS

Total Output Power, Continuous, Max 800-1200 Watts
 Voltage Adjustment Range, Min. ±5%
 Total Regulation¹, 2.0%
 Total Regulation, Standby Supply 5.0%
 Ripple & Noise, Pk-Pk² 1%
 Holdup Time 20mS
 Dynamic Response³ 300µS
 Temperature Coefficient ±0.02%/°C
 Minimum Load 0A
 Overload Protection Auto Recovery
 Overvoltage Protection Latched Shutdown
 Remote Sense Up to 0.25V Per Wire
 Current Share ±10% Full Load Rating
 Standby Output +5V, 250mA
 DC Power Good Signal Logic Low
 AC Power Fail Signal Logic High
 Global Inhibit Logic Low
 Enable Logic Low
 Thermal Warning Logic High

INPUT SPECIFICATIONS

Input Voltage Range 85-264VAC
 Power Factor 0.99
 Input Frequency 47-63Hz
 Inrush Current Limiting 50A Peak
 Input EMI Filter EN55022 Curve B
 FCC20780 pt. 15J Curve B
 Harmonic Distortion EN61000-3-2
 Input Immunity, Conducted
 Fast Transients, Line-Line .. ±2kV (EN61000-4-4 Level 3)
 Surges, Line-Line ±2kV (EN61000-4-5 Level 3)
 Surges, Line-Ground ±4kV (EN61000-4-5 Level 4)
 Input Protection Internal Fuse, 20A

GENERAL SPECIFICATIONS

Efficiency⁴ 80-85% at Full Load
 Switching Frequency, PFC Converter 48-110kHz
 Output Converter 275kHz Nominal
 Isolation, Class I, min.⁵
 Input-Output 3000VAC
 Input-Ground 1500VAC
 Output-Ground 50VDC
 MTBF (Bellcore) 200,000 Hours
 Safety Standards EN60950, UL1950, CSA22.2 No.950

ENVIRONMENTAL SPECIFICATIONS

Operating Temperature
 0°C to 70°C Ambient
 Derating 2.5% / °C, 50°C to 70°C
 Storage Temperature -40°C to +85°C
 Cooling Integral Ball Bearing Fans

PHYSICAL SPECIFICATIONS

Case Material Aluminum
 Dimensions, Inches(mm) 1.6 H x 5.0 W x 10.0 D
 (40.6 x 127 x 254)
 Weight 3.15 lbs. (1.43 kg.)

- NOTES:**
1. No load to full load, including line regulation and load regulation.
 2. 20MHz bandwidth. Measure with 0.1µF ceramic and 10µF tantalum capacitors in parallel across the output.
 3. <4% deviation recovering to within 1% for 25% load change.
 4. Typical efficiency is at low end of range for 12V output and at high end of range for 48V output.
 5. Input-output isolation figure is for isolation components only. 100% production Hipot tested.

MATING CONNECTOR KIT

Order Kit Number
775-1449-0000

MATING INTERFACE BOARD

Order Kit Number
009-3736-0000

CONNECTOR: POSITRONICS PCIB24W9M400A1 MATE:

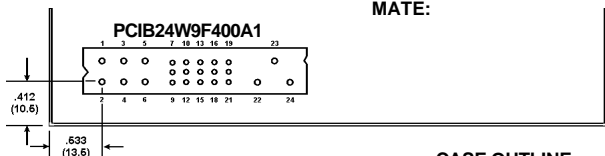

CASE OUTLINE

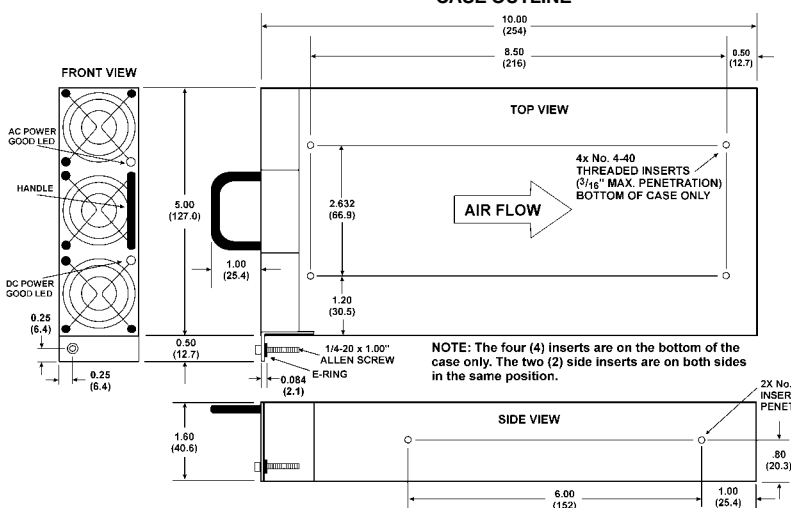

NOTE: The TCP Model is shown. The PCP version does not have handle or mounting bracket with bolt.

PIN CONNECTIONS

PIN	FUNCTION	PIN	FUNCTION
1	+V Out*	13	Module Present
2	+V Out*	14	DC Power Good/ADD GA1*
3	+V Out*	15	AC Power Fail
4	V Return*	16	V Trim
5	V Return*	17	Overtemp. Warning/ADD GA0*
6	V Return*	18	Current Share
7	Enable*	19	Current Monitor/ADD GA2*
8	+ Sense	20	+5V Standby
9	- Sense	21	Standby Return
10	Inhibit	22	Chassis Ground
11	Spare/SDA*	23	AC Line
12	Spare/SCL*	24	AC Neutral

***NOTES:** For unit to operate, pin 7 must be at logic LO or shorted to pin 9. For proper operation the following pins must be connected together: All V Out pins (1-3); all V Return pins (4-6). Pins 11, 12, 14, 17 & 19 function as I²C outputs when that option is present.

ALL DIMENSIONS IN INCHES (mm).
All specifications subject to change without notice.

pcp-tcp-revB-05-20-03.pdf